



La DT-1000A es una desmontadora automática de ruedas desarrollada según la última tecnología, funciona sin utilizar la destalonadora tradicional, libera las manos durante el trabajo.

Es una máquina ideal para las ruedas de turismos y vehículos ligeros de 14" a 28", sobre todo para las llantas grandes de aluminio de coche perfil bajo.

DATOS TÉCNICOS	
Motor	380 V
Rango de sujeción de la llanta (interno)	14" - 28"
Anchura de rueda	5" - 15"
Diámetro máximo de la rueda	1200 MM
Velocidad de giro del eje	7-13 RPM
Presión de aire	8-10 Bar
Fuerza de destalonamiento	2500 Kg
Peso neto	584 Kg
Peso bruto	692 Kg
Volumen de transporte	1680x1150x2000mm



Equipada con cámara y pantalla LCD con mando de distancia para controlar la parte inferior de la rueda.

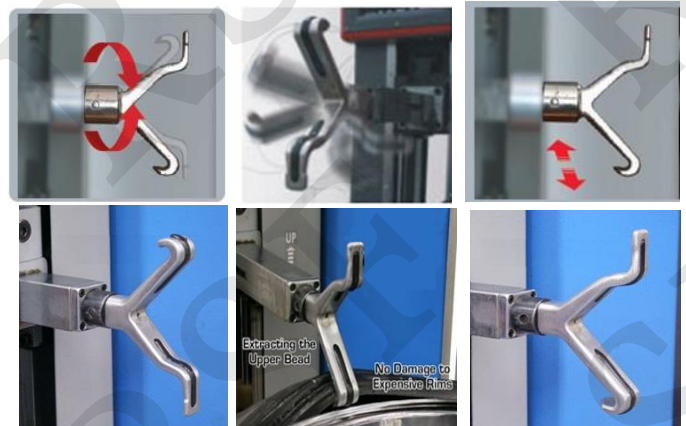

Cabezal desmontable con direcciones ←↑→↓ con barra protectora de nylon sin dañar la llanta. Giro 180° para montar o desmontar rueda.



Elevador neumático de ruedas, rodamiento extensible según medida de rueda.





Brazos destalonadores con cabezal oscilante semiautomáticos. Destalona la rueda sin tocar la llanta ni el mecanismo interior de la válvula con cabezal de contacto fabricado en APS de alta resistencia para evitar rozadura en la llanta.



Eje central variable 3 posiciones de trabajo adapta el rango de la máquina a cada tipo de rueda facilitando la incorporación de trabajo



Poste de trabajo variable. Ajustable en 2 posiciones para permitir la incorporación de llantas de grandes dimensiones.

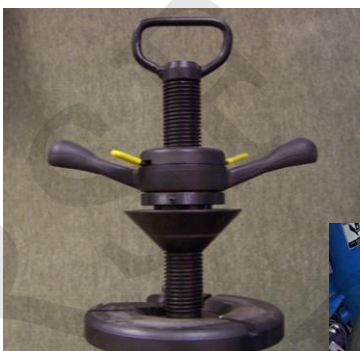

Sistema de fijación autocentrante con enganche rápido auto-click.



Jet-talonador de alto caudal para el enllantamiento instantáneo de cualquier tipo de cubierta.



DESPIECE DE PARTES DT-1000A

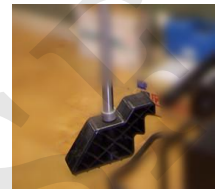
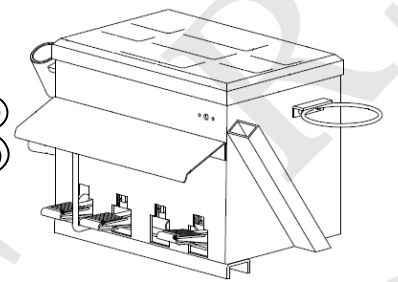
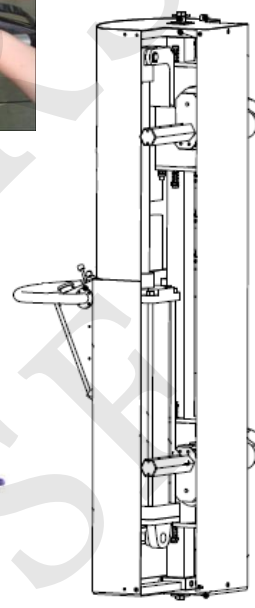
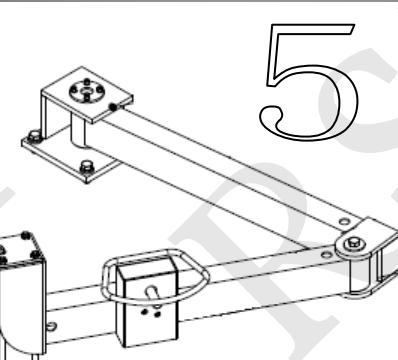
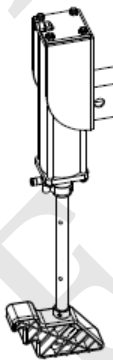
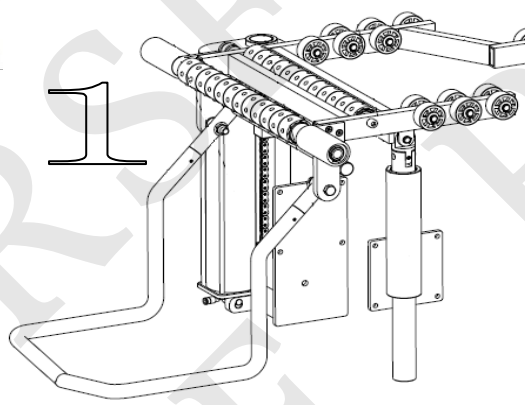
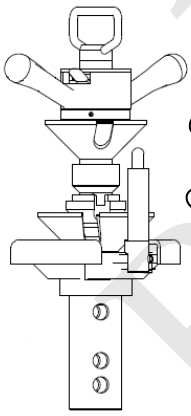
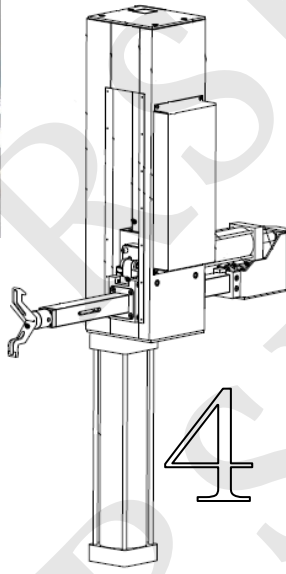

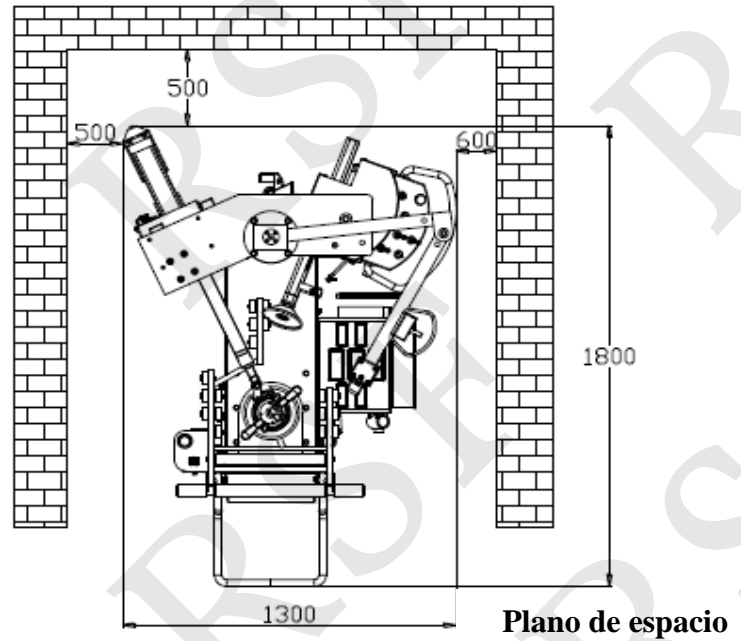
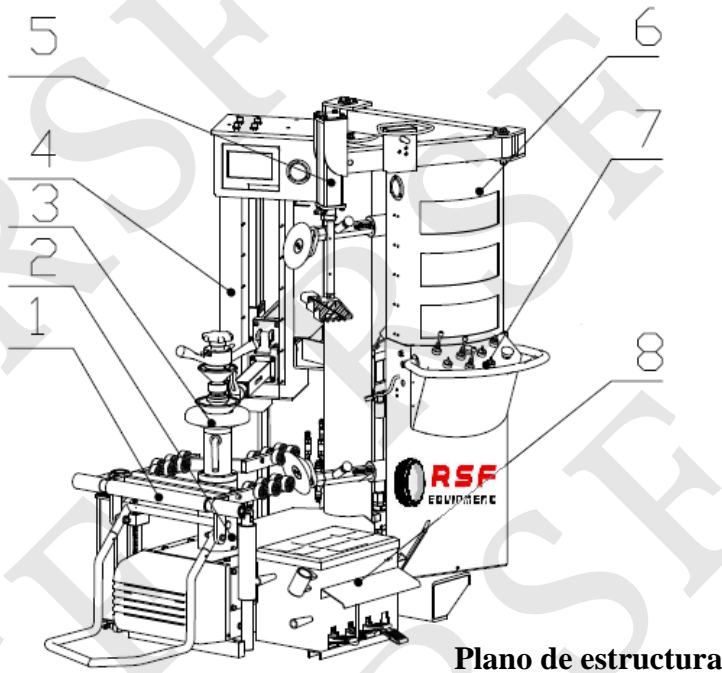

Accesorios Estándares:

1	2	3	4	5	6	7	8	9	10							
																
11	12	13	14	15	16	17										
																
1. Cono plástico 1	2. Cono plástico 2	3. Cono hierro 1	4. Cono hierro 2	5. Cono goma	6. Plato de goma	7. Util universal	8. Pasadores	9. Protector pasador	10. Protector cono	11. Plástico de cabezal	12. Mariposa 40	13. Palanca	14. Funda palanca	15. Cabezal nylon	16. Eje	17. Mando

Accesorios Opcionales:

1	2	1. Manilla desmontadora 2. Calibre para útil universal
