



	3600 kg
	50/40 sg
	2.2 kW
	220 V



Electrohydraulic 4 columns elevator for parking whose design and structure allow to double the parking spaces, parking two vehicles where previously only 1 could be parked

FEATURES

- » Max. Lifting height - **1,96 m**
- » Total height - **2,39 m**
- » Total width - **2,63 m**
- » Hydraulic motor unit for safe descent.
- » Electrical control box.
- » Mechanical unlocking system
- » Equipped with upper and lower limit switches.
- » Equipped with locking safety devices in each column
- » Possibility of mobile kit for its displacement (accessory not included)

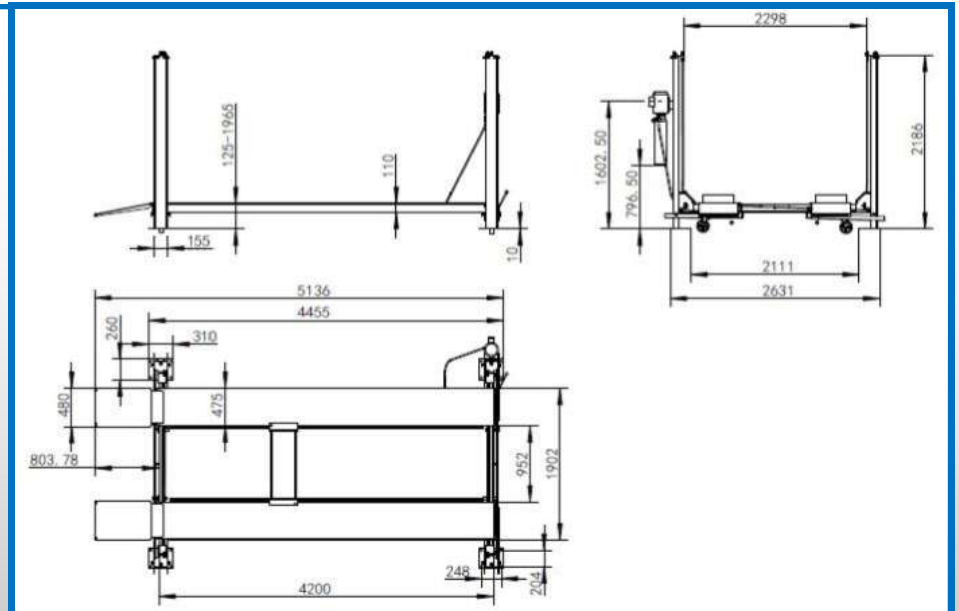

ACCESORIES NOT INCLUDED

<p>Mobile kit</p>	<p>Plastic oil pan tray</p>	<p>Sheet metal oil pan</p>	<p>Central jack</p>
-------------------	-----------------------------	----------------------------	---------------------