

	1300 mm
	13"-26"
	600 mm
	2550 kg
	0-130 bar
	1,1 kw 1,5 kw
	380V

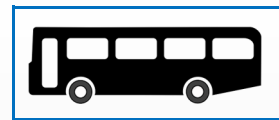

Electro-pneumatic tire changer for mobile workshop. Designed for mounting and dismounting truck, bus and industrial wheels.

FEATURES

- » 5 different rim locking positions.
- » Rim diameter: **13"-26"**
- » Max. Wheel diameter: **1.300 mm**
- » Max. Wheel width: **600 mm**
- » Max. Wheel weight: **750 kg**
- » Portable control post,
- » Automatic movement of Chuck arm and carriage

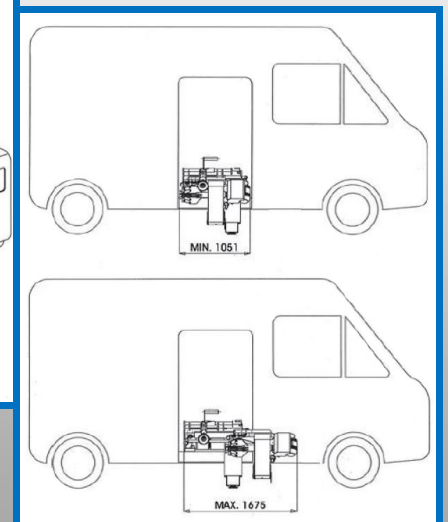
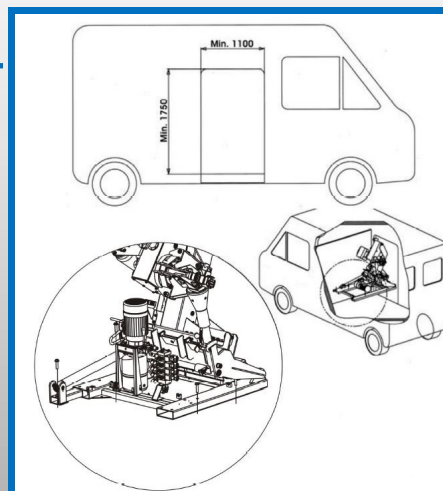

TECHNICAL DATA

Power supply	380 V
Pump power	1,1 kW
Gearbox power	1,5 kW
Rims from	13" - 26"
Max. Wheel diameter	1.300 mm
Max. Wheel width	600 mm
Max. Wheel weight	750 kg
Bead breaker force	2.550 kg
Max. Operating pressure	130 bar \pm 10%
Acoustic Pressure	< 70 dB(A)
Net weight	450 kg
Packaging Size	1070x1700x1580mm

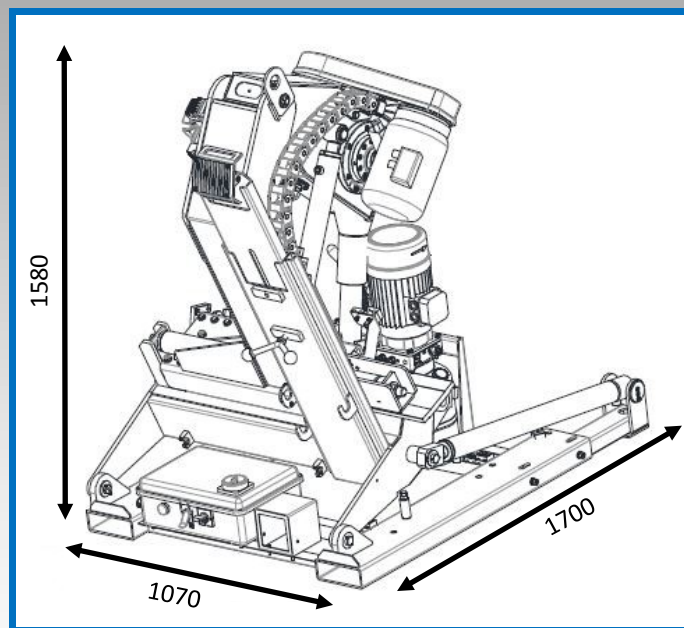

NOT INCLUDED ACCESSORIES

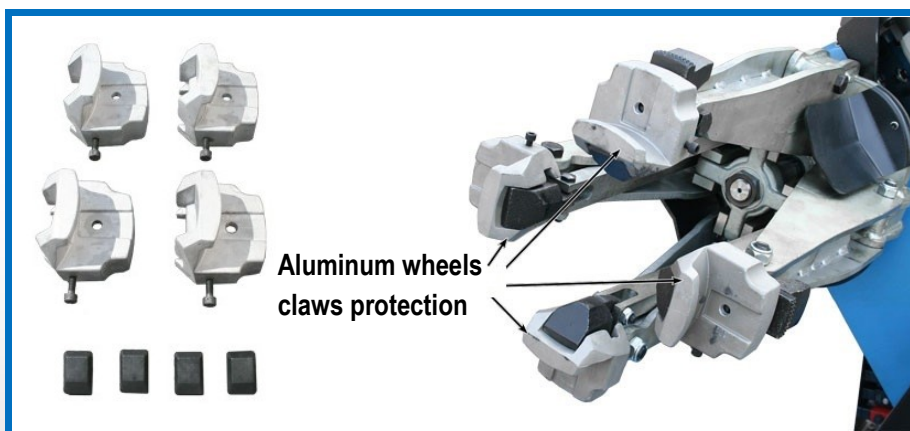

OPENING RANGE (min./max.)

